**Paints and varnishes — Bend test
(cylindrical mandrel)**

Peintures et vernis — Essai de pliage sur mandrin cylindrique

现代环境
Modern Instruments

现代环境
Modern Instruments

现代环境
Modern Instruments

现代环境
Modern Instruments

现代环境
Modern Instruments

现代环境
Modern Instruments



Reference number
ISO 1519:2011(E)

© ISO 2011

PDF disclaimer

This PDF file may contain embedded typefaces. In accordance with Adobe's licensing policy, this file may be printed or viewed but shall not be edited unless the typefaces which are embedded are licensed to and installed on the computer performing the editing. In downloading this file, parties accept therein the responsibility of not infringing Adobe's licensing policy. The ISO Central Secretariat accepts no liability in this area.

Adobe is a trademark of Adobe Systems Incorporated.

Details of the software products used to create this PDF file can be found in the General Info relative to the file; the PDF-creation parameters were optimized for printing. Every care has been taken to ensure that the file is suitable for use by ISO member bodies. In the unlikely event that a problem relating to it is found, please inform the Central Secretariat at the address given below.

现代环境
Modern Instruments

现代环境
Modern Instruments

现代环境
Modern Instruments

现代环境
Modern Instruments

现代环境
Modern Instruments



COPYRIGHT PROTECTED DOCUMENT

© ISO 2011

All rights reserved. Unless otherwise specified, no part of this publication may be reproduced or utilized in any form or by any means, electronic or mechanical, including photocopying and microfilm, without permission in writing from either ISO at the address below or ISO's member body in the country of the requester.

ISO copyright office
Case postale 56 • CH-1211 Geneva 20
Tel. + 41 22 749 01 11
Fax + 41 22 749 09 47
E-mail copyright@iso.org
Web www.iso.org

Published in Switzerland

Contents

Page

Foreword	iv
Introduction.....	v
1 Scope	1
2 Normative references.....	1
3 Principle	1
4 Apparatus	2
5 Sampling	5
6 Test panels.....	5
7 Procedure.....	6
8 Expression of results.....	7
9 Precision	7
10 Test report.....	7
Bibliography.....	9

现代环境
Modern Instruments

现代环境
Modern Instruments

现代环境
Modern Instruments

现代环境
Modern Instruments

现代环境
Modern Instruments

现代环境
Modern Instruments

Foreword

ISO (the International Organization for Standardization) is a worldwide federation of national standards bodies (ISO member bodies). The work of preparing International Standards is normally carried out through ISO technical committees. Each member body interested in a subject for which a technical committee has been established has the right to be represented on that committee. International organizations, governmental and non-governmental, in liaison with ISO, also take part in the work. ISO collaborates closely with the International Electrotechnical Commission (IEC) on all matters of electrotechnical standardization.

International Standards are drafted in accordance with the rules given in the ISO/IEC Directives, Part 2.

The main task of technical committees is to prepare International Standards. Draft International Standards adopted by the technical committees are circulated to the member bodies for voting. Publication as an International Standard requires approval by at least 75 % of the member bodies casting a vote.

Attention is drawn to the possibility that some of the elements of this document may be the subject of patent rights. ISO shall not be held responsible for identifying any or all such patent rights.

ISO 1519 was prepared by Technical Committee ISO/TC 35, *Paints and varnishes*, Subcommittee SC 9, *General test methods for paints and varnishes*.

This third edition cancels and replaces the second edition (ISO 1519:2002), which has been technically revised. The main changes are:

- a) A principle clause has been added.
- b) The requirement to carry out the test at a controlled relative humidity has been deleted (although the relative humidity is measured and recorded during the test). A maximum limit for the time between conditioning and testing has therefore been added.
- c) The supplementary test conditions (formerly Annex A) have been integrated in the test report.
- d) Information has been given on the precision of the method.

Introduction

This International Standard is one of six which specify empirical test procedures for assessing the resistance of coatings of paints, varnishes and related products to cracking and/or detachment from the substrate under different conditions of deformation.

The other five documents are:

- ISO 1520, *Paints and varnishes — Cupping test*
- ISO 6272-1, *Paints and varnishes — Rapid-deformation (impact resistance) tests — Part 1: Falling-weight test, large-area indenter*
- ISO 6272-2, *Paints and varnishes — Rapid-deformation (impact resistance) tests — Part 2: Falling-weight test, small-area indenter*
- ISO 6860, *Paints and varnishes — Bend test (conical mandrel)*
- ISO 17132, *Paints and varnishes — T-bend test*

The method chosen will depend on the property to be measured and on agreement between the interested parties. In principle, all these tests differ from each other technically and in their accuracy.

现代环境
Modern Instruments

现代环境
Modern Instruments

现代环境
Modern Instruments

现代环境
Modern Instruments

现代环境
Modern Instruments

现代环境
Modern Instruments

Paints and varnishes — Bend test (cylindrical mandrel)

1 Scope

This International Standard specifies an empirical test procedure for assessing the resistance of a coating of paint, varnish or related product to cracking and/or detachment from a metal or plastics substrate when subjected to bending round a cylindrical mandrel under standard conditions.

For a multi-coat system, each coat can be tested separately or the complete system can be tested.

The method specified can be carried out

- either as a “pass/fail” test, by carrying out the test with a single specified size of mandrel, to assess compliance with a particular requirement;
- or by repeating the procedure using successively smaller mandrels to determine the diameter of the first mandrel over which the coating cracks and/or becomes detached from the substrate.

Two types of apparatus are specified, type 1 being appropriate for use on test panels of thickness up to 0,3 mm, and type 2 for use on test panels of thickness up to 1,0 mm. Both types of apparatus have been found to give similar results with the same coating, but normally only one will be used for testing a given product.

2 Normative references

The following referenced documents are indispensable for the application of this document. For dated references, only the edition cited applies. For undated references, the latest edition of the referenced document (including any amendments) applies.

ISO 1513, *Paints and varnishes — Examination and preparation of test samples*

ISO 1514, *Paints and varnishes — Standard panels for testing*

ISO 2808, *Paints and varnishes — Determination of film thickness*

ISO 15528, *Paints, varnishes and raw materials for paints and varnishes — Sampling*

3 Principle

A coated test panel is clamped in the test apparatus and then bent round a cylindrical mandrel. The bent panel is examined to see if the coating has been cracked when using the agreed or specified size of mandrel (“pass/fail test”) or, alternatively, the diameter of the first (smallest) mandrel over which the coating cracks and/or becomes detached from the substrate is determined.

4 Apparatus

4.1 Bend test apparatus

4.1.1 Material

In both types of apparatus specified below, the mandrels shall be made of a rigid and suitably corrosion-resistant material, for example stainless steel.

4.1.2 Type 1 mandrel tester

An example of a type 1 tester is shown in Figures 1 and 2. This type of tester is used with test panels of thickness not greater than 0,3 mm. A set of hinges is provided, each incorporating a cylindrical mandrel. The diameters of the mandrels are 2 mm, 3 mm, 4 mm, 5 mm, 6 mm, 8 mm, 10 mm, 12 mm, 16 mm, 20 mm, 25 mm and 32 mm, respectively, with a tolerance of $\pm 0,1$ mm. The dimensions of the apparatus are not critical, except that the gap between the surface of the mandrel and the plates of the hinges shall be $(0,55 \pm 0,05)$ mm. The mandrel shall be free to rotate on its axis and the apparatus shall be provided with a stop to ensure that, when the test panel is bent, the two parts are parallel.

Especially with the 2 mm diameter mandrel, it is important to ensure that no distortion of the mandrel takes place during the bending process, and not to use any mandrel showing such distortion.

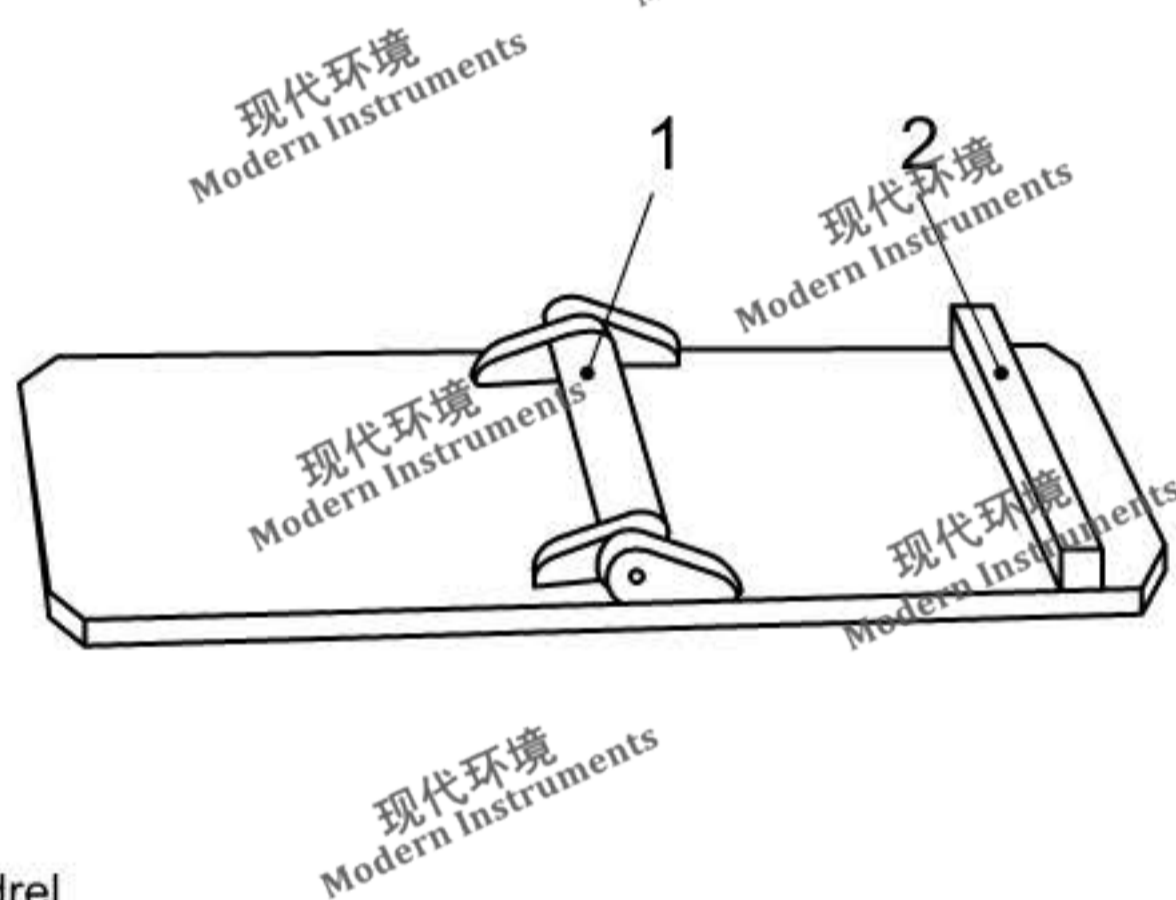

Key

- 1 mandrel
- 2 stop of similar height to mandrel

Figure 1 — Type 1 bend test apparatus



Figure 2 — Type 1 bend test apparatus in use

4.1.3 Type 2 mandrel tester

An example of a type 2 tester is shown in Figures 3 and 4. Type 2 testers are normally used for panels with a thickness of up to 1,0 mm. With coatings on soft metals, for example aluminium, and on plastics, thicker panels may be used with the provision that there is no deformation of the mandrel (see 6.3). The diameters of the mandrels are 2 mm, 3 mm, 4 mm, 5 mm, 6 mm, 8 mm, 10 mm, 12 mm, 16 mm, 20 mm, 25 mm and 32 mm, with a tolerance of $\pm 0,1$ mm.

By agreement between the interested parties, mandrels of other diameters may be used with the type 2 tester.

NOTE The bending piece of the type 2 tester, illustrated as an example in Figures 3 and 4, consists of three PVC rolls which are arranged side by side and run on pivoting bearings. Thus, the coating is not exposed to damage or shear stress during the test.

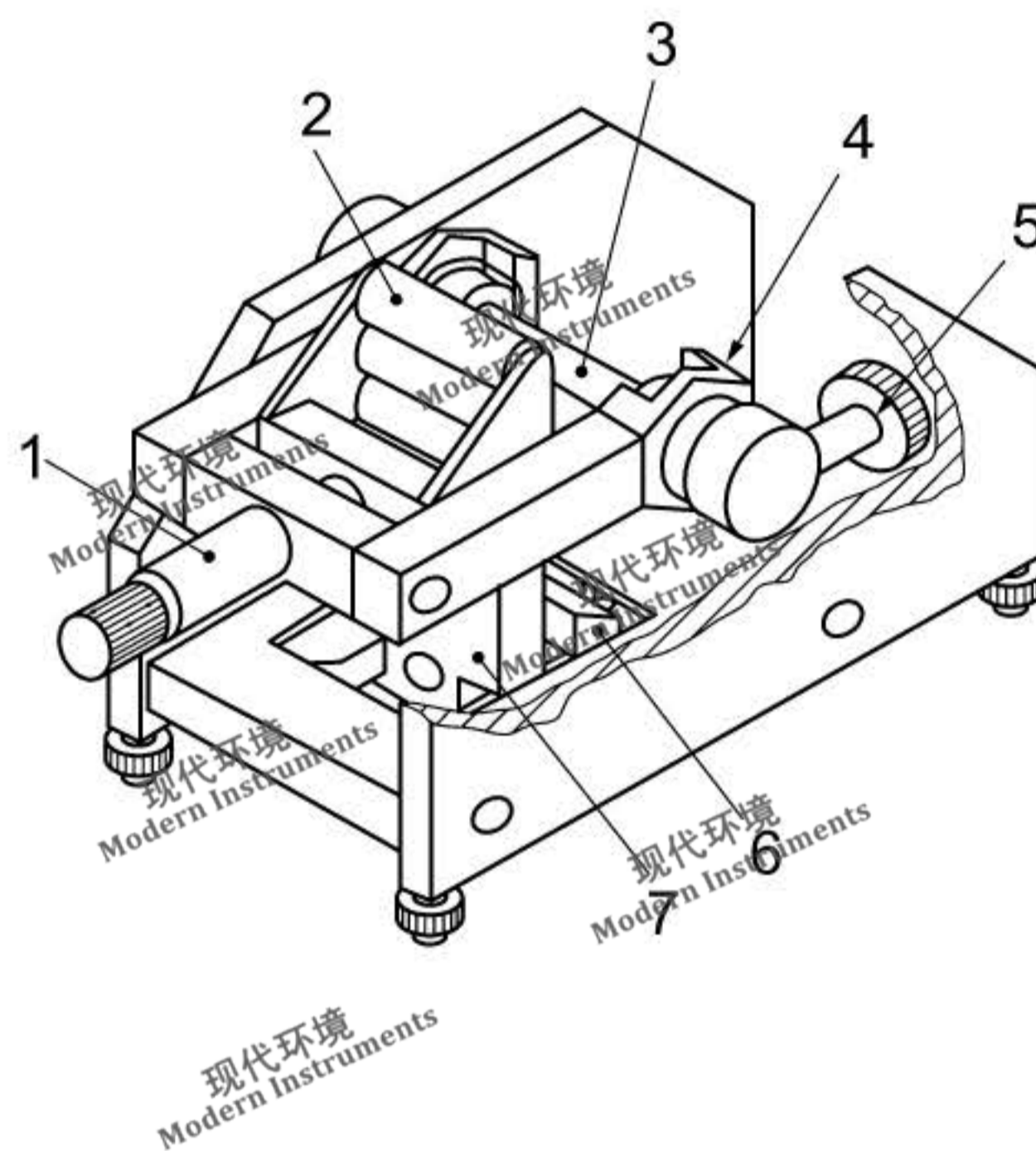

Key

- 1 screw handle
- 2 bending piece
- 3 mandrel
- 4 mandrel bearing
- 5 adjusting screw
- 6 clamping jaw
- 7 thrust bearing

Figure 3 — Example of a type 2 mandrel bending tester

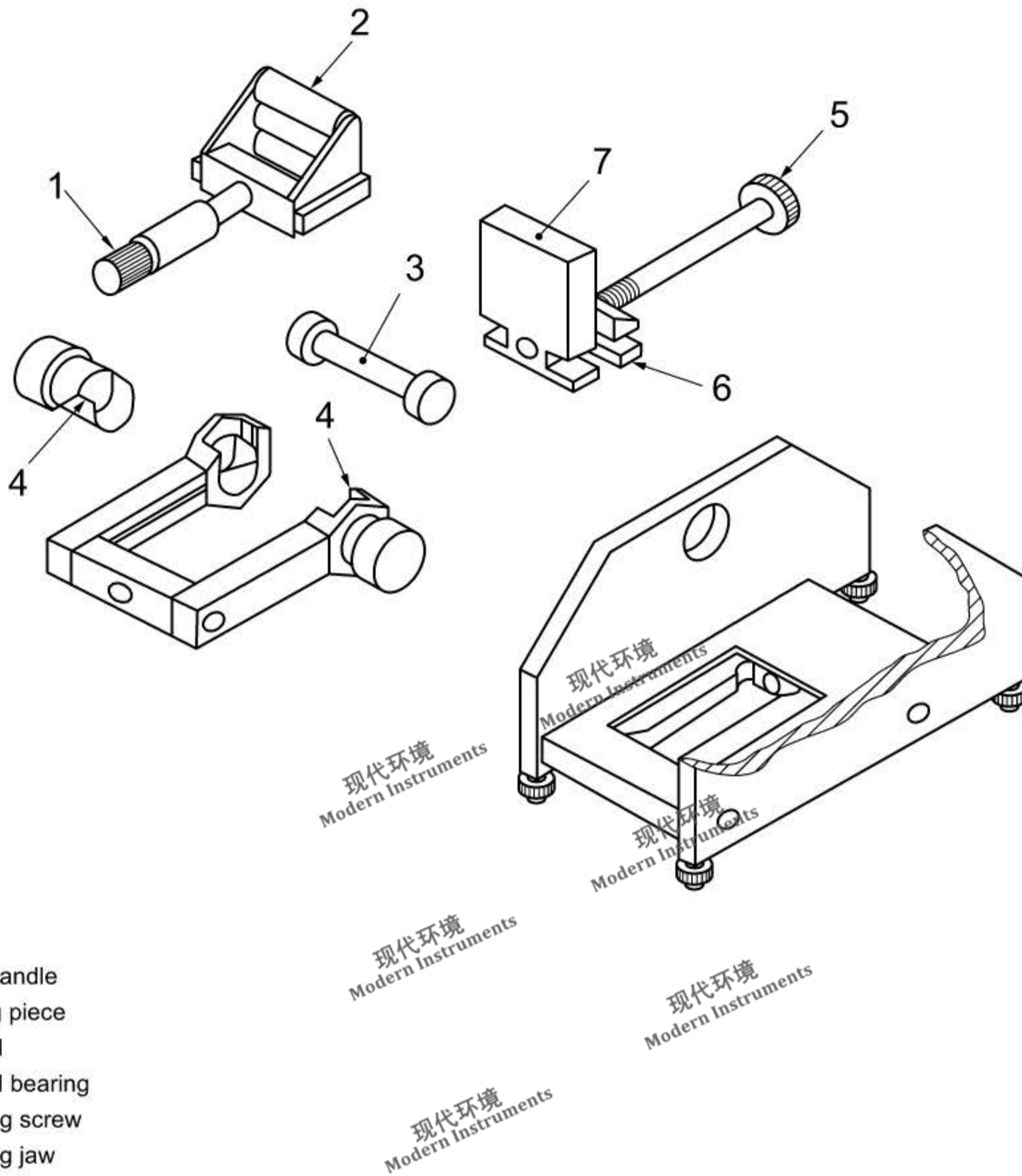

- Key**
- 1 screw handle
 - 2 bending piece
 - 3 mandrel
 - 4 mandrel bearing
 - 5 adjusting screw
 - 6 clamping jaw
 - 7 thrust bearing

Figure 4 — Exploded diagram of the tester shown in Figure 3

4.2 Controlled-temperature chamber

This is required for tests which are specified to be carried out at temperatures other than $(23 \pm 2) ^\circ\text{C}$. It consists of an oven or refrigerator in which the temperature of the chamber can be controlled to within $\pm 1 ^\circ\text{C}$ of the required test temperature.

A temperature-indicating or recording device shall be located with its bulb or sensitive element in close proximity to the coating under test.

NOTE A remote-control device by means of which the test panel can be bent without opening the chamber can be helpful in performing the test without causing any change in the test temperature.

4.3 Magnifying lens

A lens with $\times 10$ magnification is required.

5 Sampling

Take a representative sample of the product to be tested (or of each product in the case of a multi-coat system), in accordance with ISO 15528.

Examine and prepare each sample for testing, in accordance with ISO 1513.

6 Test panels

6.1 Substrate

The test panels shall be of steel, tinplate or soft aluminium complying with the requirements of ISO 1514.

Plastics substrates are also suitable and may be used subject to agreement between the interested parties.

6.2 General

The test panels shall be flat and free from distortion, and both the front and the back shall be free from any visible ridges or cracks.

6.3 Shape and dimensions

The test panels shall be rectangular. The dimensions of the test panel shall be chosen so that it can be cut into three strips of at least 30 mm in width. The size and the thickness of the strips will depend on the type of tester, either 0,3 mm thick (for type 1) or 1,0 mm (for type 2), unless otherwise specified. If use of plastics panels is agreed, a thickness of up to 4,0 mm may be used.

The test panels may be cut to size after coating and drying, provided no distortion occurs. In the case of aluminium panels, the longer side shall be parallel to the direction of rolling during manufacture.

The thickness and the nature of the substrate shall be reported in the test report.

6.4 Preparation and coating of panels

Prepare each test panel in accordance with ISO 1514 and coat it by the specified method with the product or system under test.

If the product under test is applied by brushing, the brush marks shall be parallel to the longer side of the panel.

6.5 Drying and conditioning

Dry (or stove) and age, if applicable, each coated test panel for the specified time under the specified conditions. Before testing, condition the coated panels at a temperature of (23 ± 2) °C and a relative humidity of (50 ± 5) % (i.e. in accordance with ISO 3270), unless otherwise agreed, for a minimum period of 16 h. Carry out the test procedure as soon as possible but in any case not later than 30 min after removal of the test panels from conditioning.

6.6 Thickness of coating

Determine the thickness, in micrometres, of the dried coating by one of the procedures specified in ISO 2808.

6.7 Cutting of test panels

Cut the test panels into three strips of at least 30 mm in width.

7 Procedure

7.1 Test conditions

Carry out the test at a temperature of (23 ± 2) °C. Measure the relative humidity during the test and state it in the test report.

7.2 Procedure for a single specified size of mandrel

7.2.1 General

Carry out the appropriate procedure given in 7.2.2, 7.2.3 or 7.2.4 on two separate test panels and then examine the panels as specified in 7.2.5. If the results differ, additional tests shall be carried out.

7.2.2 Tests with the type 1 apparatus

Fully open the apparatus, fitted with the appropriate mandrel, and insert a panel so that it will subsequently be bent with the coated side outwards.

Close the apparatus at a steady rate without jerking, over a period of 1 s to 2 s, thus bending the panel through 180° over the mandrel.

7.2.3 Tests with the type 2 apparatus

Place or secure the tester (see Figure 3) so that it cannot be displaced during the test procedure and the screw handle can be operated freely, for example near the edge of a bench. Insert a test panel, from the top, between the bending piece and the mandrel as well as between the thrust bearing and the clamping jaw, with the coating to be tested facing away from the mandrel. Pull the adjusting screw to move the thrust bearing so that the test panel is placed in a vertical position touching the mandrel. Fix the test panel in this position with the clamping jaw by turning the adjusting screw. Using the screw handle, move the bending piece until it touches the coating. The actual bending procedure is carried out by lifting the screw handle at a steady rate through 180° over a period of 1 s to 2 s, thus bending the test panel through 180°.

A piece of thin paper may be inserted over the coated surface between the panel holder and the bending piece to prevent the coating being scratched during the bending operation.

Remove the test panel from the tester by moving the screw handle back to its starting position. Then release the bending piece and clamping jaw using the appropriate operating elements (screw handle, adjusting screw).

7.2.4 Testing at temperatures other than (23 ± 2) °C

Place the panel in position in a type 1 or a type 2 apparatus so that it will subsequently be bent with the coated side outwards. Place the tester containing the panel in the controlled-temperature chamber previously brought to the specified temperature. After 2 h, with the panel still in the chamber at the specified temperature, perform the bending procedure (see 7.2.2 or 7.2.3) over a period of 1 s to 2 s, thus bending the test panel through 180°. It is essential that the door of the chamber remain closed from the time of insertion of the apparatus until immediately before the bending operation.

7.2.5 Examination of the test panel

Examine the coating immediately after bending under good illumination and, in the case of the type 1 tester, without removing the panel from the apparatus. Use normal corrected vision or, by agreement, a lens of $\times 10$ magnification, and examine the coating for cracking and/or detachment from the substrate, ignoring the surface of the coating less than 10 mm from the edge of the panel.

If a lens is used, it is essential to mention this fact in the test report in order to avoid misleading comparisons with results obtained using normal vision only.

7.3 Determination of the diameter of the first mandrel to cause failure

Carry out the appropriate procedure given in 7.2.2, 7.2.3 or 7.2.4 on successive test panels, examining each panel as specified in 7.2.5 and using mandrels of successively smaller diameter until the coating cracks and/or becomes detached from the substrate. Record the diameter of the first mandrel with which the coating cracks and/or becomes detached, after confirming the result by repeating the procedure with this size of mandrel on a fresh panel. In the event of failure not occurring with the mandrel of the smallest diameter, record this fact.

8 Expression of results

8.1 Single mandrel

Report the result of the examination of the panels (see 7.2.5) as the extent of cracking and/or detachment of the coating from the substrate, with the specified size of mandrel.

8.2 Diameter of the first mandrel to cause failure

Report the result as the diameter of the first mandrel with which the coating cracked and/or became detached from the substrate, or the fact that failure did not occur with the smallest-diameter mandrel used. In the latter case, the diameter of the smallest-diameter mandrel shall also be stated.

9 Precision

The method described in this International Standard should be regarded as an indicative test only and not one that can be expected to give precise results. The reproducibility limit, (R), determined in an interlaboratory test by six participants testing two paint systems was estimated to be 50 % and is stated here simply to give an approximate indication of the precision.

10 Test report

The test report shall include the following information:

- a) all details necessary to identify the product tested;
- b) a reference to this International Standard (ISO 1519);
- c) details of the preparation of the test panels, including the following:
 - 1) the material, thickness and surface preparation of the substrate (see 6.1 to 6.3),
 - 2) the method of application of the test coating to the substrate, including the duration and conditions of drying between coats in the case of a multi-coat system (see 6.4),
 - 3) the duration and conditions of drying (or stoving) of the coating, and the conditions of ageing, if applicable, before testing (see 6.5),
 - 4) the thickness, in micrometres, of the dry coating and the method from ISO 2808 used to measure it, and whether the coating is a single coating or a multi-coat system (see 6.6);
- d) the type of apparatus used (type 1 or type 2);
- e) the specified size of mandrel, if applicable, used in the test;

ISO 1519:2011(E)

- f) the temperature and relative humidity during the test (see 7.1);
- g) the result of the test, reported in accordance with Clause 8 (and stating whether normal corrected vision or a magnifying lens was used);
- h) any deviation, by agreement or otherwise, from the test procedure specified;
- i) any unusual features (anomalies) observed during the test;
- j) the date of the test.

现代环境
Modern Instruments

现代环境
Modern Instruments

现代环境
Modern Instruments

现代环境
Modern Instruments

现代环境
Modern Instruments

Bibliography

- [1] ISO 3270, *Paints and varnishes and their raw materials — Temperatures and humidities for conditioning and testing*

现代环境
Modern Instruments

现代环境
Modern Instruments

现代环境
Modern Instruments

现代环境
Modern Instruments

现代环境
Modern Instruments

现代环境
Modern Instruments

现代环境
Modern Instruments

现代环境
Modern Instruments

现代环境
Modern Instruments

现代环境
Modern Instruments

现代环境
Modern Instruments

现代环境
Modern Instruments

ICS 87.040

Price based on 9 pages