**Paints and varnishes — Rapid-
deformation (impact resistance) tests —**

Part 1:

Falling-weight test, large-area indenter

Peintures et vernis — Essais de déformation rapide (résistance au choc) —

Partie 1: Essai de chute d'une masse avec pénétrateur de surface importante



现代环境
Modern Instruments

现代环境
Modern Instruments

现代环境
Modern Instruments

现代环境
Modern Instruments

现代环境
Modern Instruments

现代环境
Modern Instruments



COPYRIGHT PROTECTED DOCUMENT

© ISO 2011

All rights reserved. Unless otherwise specified, no part of this publication may be reproduced or utilized in any form or by any means, electronic or mechanical, including photocopying and microfilm, without permission in writing from either ISO at the address below or ISO's member body in the country of the requester.

ISO copyright office
Case postale 56 • CH-1211 Geneva 20
Tel. + 41 22 749 01 11
Fax + 41 22 749 09 47
E-mail copyright@iso.org
Web www.iso.org

Published in Switzerland

Contents

Page

Foreword.....	iv
1 Scope.....	1
2 Normative references.....	1
3 Principle.....	1
4 Apparatus.....	2
5 Sampling.....	2
6 Test panels.....	4
7 Procedure.....	5
8 Precision.....	6
9 Test report.....	7

Foreword

ISO (the International Organization for Standardization) is a worldwide federation of national standards bodies (ISO member bodies). The work of preparing International Standards is normally carried out through ISO technical committees. Each member body interested in a subject for which a technical committee has been established has the right to be represented on that committee. International organizations, governmental and non-governmental, in liaison with ISO, also take part in the work. ISO collaborates closely with the International Electrotechnical Commission (IEC) on all matters of electrotechnical standardization.

International Standards are drafted in accordance with the rules given in the ISO/IEC Directives, Part 2.

The main task of technical committees is to prepare International Standards. Draft International Standards adopted by the technical committees are circulated to the member bodies for voting. Publication as an International Standard requires approval by at least 75 % of the member bodies casting a vote.

Attention is drawn to the possibility that some of the elements of this document may be the subject of patent rights. ISO shall not be held responsible for identifying any or all such patent rights.

ISO 6272-1 was prepared by Technical Committee ISO/TC 35, *Paints and varnishes*, Subcommittee SC 9, *General test methods for paints and varnishes*.

This second edition cancels and replaces the first edition (ISO 6272-1:2002), which has been technically revised. The main technical changes are as follows:

- a) in the description of the guide tube (see 4.1.3) and in Figure 1, the play permitted between the guide tube and the falling weight has been changed;
- b) a “principle” clause has been added;
- c) the test is no longer carried out at a specified relative humidity; instead, the relative humidity is simply recorded but the test has to be completed within a specified length of time after conditioning the test panels;
- d) the supplementary test conditions (formerly Annex A) have been incorporated in the test report.

ISO 6272 consists of the following parts, under the general title *Paints and varnishes — Rapid-deformation (impact resistance) tests*:

- *Part 1: Falling-weight test, large-area indenter*
- *Part 2: Falling-weight test, small-area indenter*

Paints and varnishes — Rapid-deformation (impact resistance) tests —

Part 1: Falling-weight test, large-area indenter

1 Scope

This part of ISO 6272 describes a method for evaluating the resistance of a dry film of paint, varnish or related product to cracking or peeling from a substrate when it is subjected to a deformation caused by a falling weight, with a 20-mm-diameter spherical indenter, dropped under standard conditions.

NOTE The terms “impact” and “impact resistance” are used in the title and text of this part of ISO 6272, but an important characteristic of the apparatus used is that it should produce rapid deformation rather than a true impact.

The method described can be applied

- either as a pass/fail test, the test being carried out from one drop height and with a specified mass, so as to test compliance with a particular specification;
- or as a classification test, to determine, by gradually increasing the drop height and/or the mass, the minimum mass and/or drop height for which the coating cracks or peels from its substrate.

2 Normative references

The following referenced documents are indispensable for the application of this document. For dated references, only the edition cited applies. For undated references, the latest edition of the referenced document (including any amendments) applies.

ISO 1513, *Paints and varnishes — Examination and preparation of test samples*

ISO 1514, *Paints and varnishes — Standard panels for testing*

ISO 2808, *Paints and varnishes — Determination of film thickness*

ISO 3270, *Paints and varnishes and their raw materials — Temperatures and humidities for conditioning and testing*

ISO 13076, *Paints and varnishes — Lighting and procedure for visual assessments*

ISO 15528, *Paints, varnishes and raw materials for paints and varnishes — Sampling*

3 Principle

The coating under test is applied to suitable, thin (normally metal) panels. After the coating has cured, a standard weight is dropped on to each panel from a height that will cause deformation of the coating and the substrate. The test can be carried out with the coated side of the panel facing upwards (i.e. towards the falling

weight) or downwards (i.e. away from the weight). By gradually increasing the height from which the weight drops, the point at which failure occurs can be determined. Films generally fail by cracking, which is made more visible by the use of a magnifier.

4 Apparatus

Ordinary laboratory apparatus and glassware, together with the following:

4.1 Falling-weight apparatus, comprising the elements described in 4.1.1 to 4.1.6.

4.1.1 Base stand, of sufficient mass to support the die (4.1.4).

4.1.2 Falling weights (see Figure 1), the head having the shape of a spherical segment of diameter $(20 \pm 0,3)$ mm, and a total mass of $(1\ 000 \pm 10)$ g or $(2\ 000 \pm 20)$ g, unless otherwise specified.

4.1.3 Vertical guide tube (see Figures 1 and 2), to direct the falling weight (4.1.2) perpendicularly on to the test panel. The guide tube shall be graduated in millimetres to indicate the distance above the surface of the test panel.

To avoid excessive friction and to ensure accurate guidance, the difference between the inner diameter of the guide tube and the outer diameter of the falling weight shall be $(0,7 \pm 0,2)$ mm and the distance between the bottom end of the guide tube and the top of the test panel shall be not more than 45 mm.

4.1.4 Die (see Figure 1), ring-shaped with an inner diameter of $(27 \pm 0,3)$ mm. The inner upper edge of the ring shall be rounded, with a radius of curvature of $(0,9 \pm 0,2)$ mm. The minimum height of the ring shall be 20 mm.

4.1.5 Clamping sleeve (see Figures 1 and 2), to hold the test panel in position. The inner diameter at the bottom shall be the same as that of the die [$(27 \pm 0,3)$ mm]; however, it is important to ensure that the head of the weight can travel smoothly through the clamping sleeve.

4.1.6 Stops (see Figure 2), of different thicknesses, to limit the indentation depth of the falling weight.

4.2 Viewing lens, with a magnification of $\times 10$.

5 Sampling

Take a representative sample of the coating material to be tested (or of each product in the case of a multi-coat system), as described in ISO 15528.

Examine and prepare each sample for testing, as described in ISO 1513.

Dimensions in millimetres

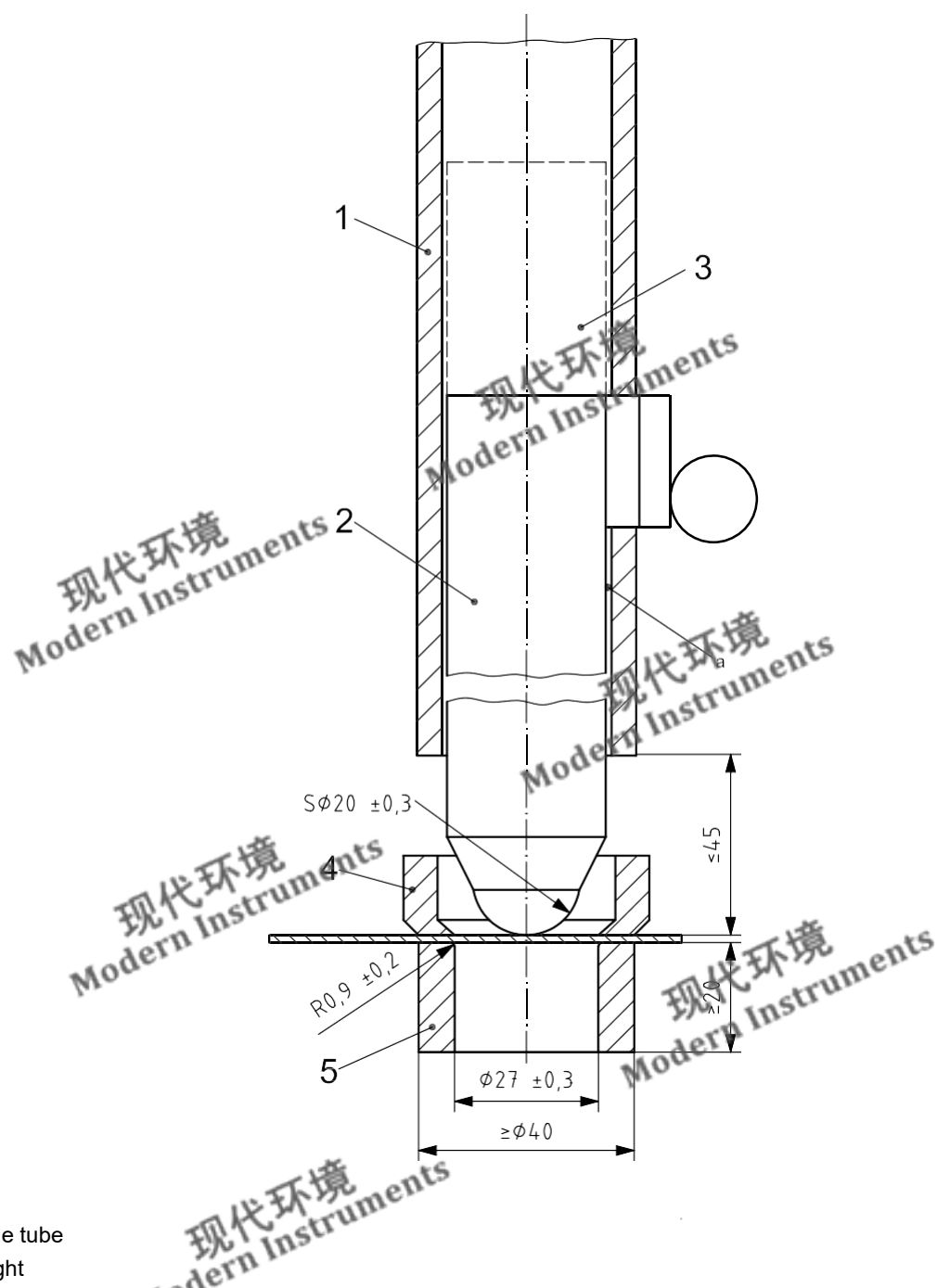
**Key**

- 1 guide tube
- 2 weight
- 3 additional weight(s) if required
- 4 clamping sleeve
- 5 die

^a The difference between the inner diameter of the guide tube and the outer diameter of the falling weight is $(0,7 \pm 0,2)$ mm.

Figure 1 — Falling-weight apparatus showing required dimensions

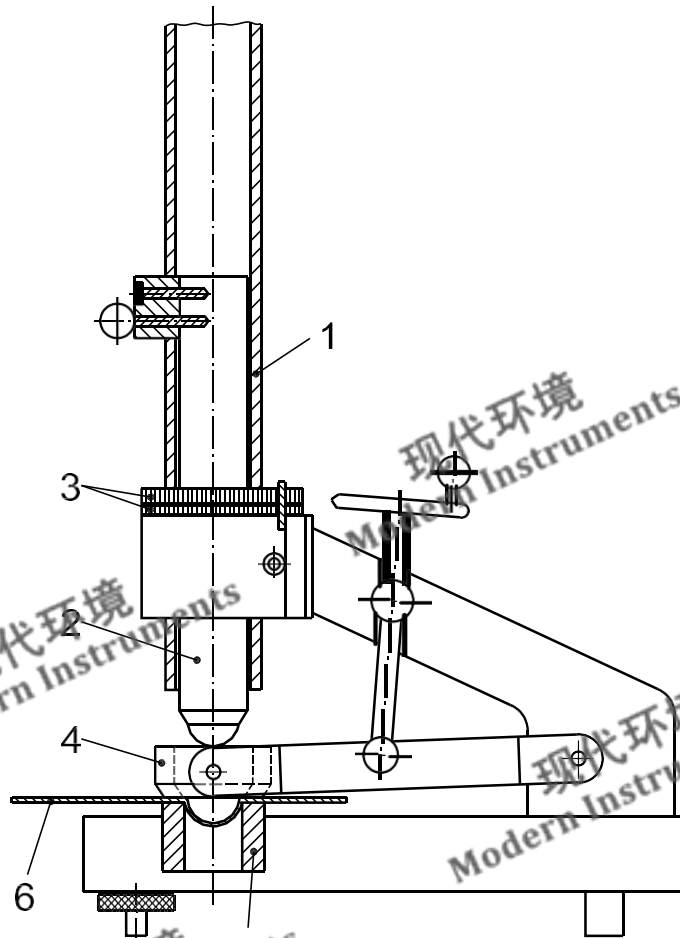

- Key**
- 1 guide tube
 - 2 falling weight
 - 3 stops
 - 4 clamping sleeve
 - 5 die
 - 6 test panel

Figure 2 — Side view of falling-weight apparatus

6 Test panels

6.1 Substrate

If a metal panel is used, it shall conform to the requirements of ISO 1514.

Whatever the panel material, the panels shall be planar, free from distortion and at least 0,25 mm thick. The dimensions shall be such as to allow the test to be carried out at at least five different positions not less than 40 mm from each other and not less than 20 mm from the edge of the panel.

Measure the thickness to the nearest 0,01 mm.

6.2 Preparation and coating

Prepare metal test panels in accordance with ISO 1514.

Whatever the panel material, coat the prepared panel by the method specified by the manufacturer of the product or system under test to give the dry-film thickness specified by the manufacturer, or by a method agreed upon between the interested parties to give a dry-film thickness agreed upon between the interested parties.

The coating method and dry-film thickness used shall be included in the test report [see Clause 9, items c) 2) and c) 4)].

6.3 Drying

Dry (or stove) and age (if applicable) each coated test panel for the time, and under the conditions, specified by the manufacturer of the product or system under test, or as agreed between the interested parties.

The time and conditions used shall be included in the test report [see Clause 9, item c) 3)].

6.4 Thickness of coating

Determine the thickness, in micrometres, of the dried coating by one of the procedures specified in ISO 2808. Make the measurements at, or as near as possible to, the positions at which the test is to be carried out.

Use only test panels for which the film thickness values do not differ from the specified or agreed film thickness by more than 10 %.

7 Procedure

7.1 General

Before testing, condition the coated panels at a temperature of $(23 \pm 2)^\circ\text{C}$ and a relative humidity of $(50 \pm 5)\%$ (or at another temperature and humidity, agreed between the interested parties, from those specified in ISO 3270) for a minimum period of 16 h. Begin the test procedure as soon as possible after conditioning, but in any case complete it not later than 30 min after removal of the test panels from conditioning.

Mount the apparatus on a firm surface (for example, concrete, steel or stone).

Carry out the test at $(23 \pm 2)^\circ\text{C}$ or at another temperature, agreed between the interested parties, from those specified in ISO 3270. State the test temperature at which the test was carried out in the test report.

Measure the relative humidity during the test and state it in the test report.

7.2 Pass/fail test (using a specified mass)

Ensure that the guide tube (4.1.3) is vertical. Attach additional weight(s), if required, to the weight in order to achieve the required loading.

Adjust the height of the weight to the required release-point (using the graduations on the guide tube) and lock in position. If necessary, fit stop(s) (4.1.6) of total thickness sufficient to limit the indentation to a depth agreed between the interested parties or as otherwise specified. Place a test panel (see Clause 6) on the die (4.1.4), with the coated face up or down, as specified. Hold the test panel in position by means of the clamping sleeve. Release the weight (4.1.2) and allow it to fall on to the test panel.

Remove the test panel from the apparatus and examine the coating with the lens (4.2).

Report whether the coating on the test panel has cracked or has peeled from the substrate and whether or not the substrate has cracked.

Repeat the test a further four times at different positions, giving a total of five drops. Report the coating as satisfactory if at least four test positions show no cracking or peeling from the substrate.

7.3 Classification test (to determine the minimum drop height and mass which will cause cracking or peeling)

7.3.1 Ensure that the guide tube (4.1.3) is vertical. Adjust the height of the weight (4.1.2) to the position where it is expected that no failure will occur and lock in position. Place a test panel on the die (4.1.4) with the coated face up or down, as specified or agreed upon. Hold the test panel in position by means of the clamping sleeve. Release the weight (4.1.2) and allow it to fall on to the test panel.

7.3.2 Remove the test panel from the apparatus and examine the deformed area with the lens (4.2) for coating cracks and/or peeling from the substrate. If no cracks and/or peeling are evident, repeat the procedure at successively greater heights until cracks and/or peeling are observed, the increments in the height being 25 mm or multiples of 25 mm. Note the height where cracks and/or peeling are observed for the first time.

If no cracks and/or peeling are observed when the weight is dropped from the maximum height allowed by the apparatus, repeat the operation (starting at the lowest height setting) with an additional weight, making a total of 2 kg.

If no cracks and/or peeling are observed, repeat the operation (starting at the lowest height setting) with a further additional weight, making a total of 3 kg. Where required, a final additional weight may be added to give a maximum mass of 4 kg.

7.3.3 Once cracks and/or peeling are observed, carry out the following procedure. Release the appropriate weight and allow it to fall on to a test panel five times at different positions from each of the following heights:

- the height where cracks and/or peeling were first observed during the procedure described in 7.3.2;
- 25 mm below this height.

Test in a random fashion, taking care that not all impacts from one height are made in succession on one panel.

7.3.4 Examine, using the lighting and the procedure specified in ISO 13076, the relevant areas of the coating with the lens (4.2) for cracking and/or peeling from the substrate and tabulate all results as pass or fail. Report as the end point of the test the mass/height combination for which the results change from mainly passing to mainly failing.

7.3.5 If no end point can be established, repeat the procedure in 7.3.3 and 7.3.4, taking all heights 25 mm higher or lower, as appropriate, to ensure that the end point of the test is covered by the range of heights tested.

8 Precision

No precision data are currently available.

9 Test report

The test report shall contain at least the following information:

- a) all details necessary to identify the product tested;
- b) a reference to this part of ISO 6272 (ISO 6272-1:2011);
- c) details of the panels and their preparation, including the following:
 - 1) the material, thickness and surface preparation of the substrate (see 6.1),
 - 2) the method of application of the test coating to the substrate, including the duration and conditions of drying between coats in the case of a multi-coat system (see 6.2),
 - 3) the duration and conditions of drying (or stoving) the coat and ageing (if applicable) of the coat before testing (see 6.3),
 - 4) the thickness, in micrometres, of the dry coating and the method of measurement used from ISO 2808 (see 6.4), and whether it is a single coating or a multi-coat system;
- d) the temperature and relative humidity during the test;
- e) the procedure carried out, i.e. whether it was a pass/fail or a classification test;
- f) the mass of the falling weight;
- g) the height, if appropriate, from which the weight was dropped;
- h) whether the falling weight struck the coated face of the test panel or the uncoated face, or both;
- i) whether or not stops were used to limit the penetration depth of the falling weight (if so, state the total thickness);
- j) the result of the test as indicated in 7.2 or 7.3;
- k) any deviation from the test method specified;
- l) any unusual features (anomalies) observed during the test;
- m) the date of the test.